

Solid waste management strategy as an alternative energy source for the economic driver in Gading Kasri Malang City

Dwi Arman Prasetya¹, Anwar Sanusi², Grahita Chandrarin³, Elfiatur Roikhah⁴, Rahman Arifuddin⁵, Puput Dani Prasetyo Adi⁶

^{1,5,6}Electrical Engineering Department, Engineering Faculty, University of Merdeka Malang, Indonesia

^{2,3,4}Economics and Business faculty, University of Merdeka Malang Indonesia

ABSTRACT

The economic factor is one of the keys to an area that can be advanced and independent. Until now, the community is still dependent on expensive fuel, while using raw materials around the Gading Kasri village is the right idea. One of the pictures to improve the community's economic factor in the Gading Kasri village is how to convert waste into fuel. The benefits obtained are substantial, including helping the community's economy, reducing plastic waste, and turning plastic waste into energy that is useful for cooking, starting motorbikes, and other powers. In this research, the design of the Combustion Optimization Tool for the Distillation of Plastic Waste into Oil Fuel (BBM) was made as an effective solution to produce an energy source in the form of gas oil with a maximum volume when compared to previous designs for similar devices. In this design, a plastic waste burner cross-section is made in the form of a circular crossbar so that the volume of waste and the effectiveness of combustion that is collected can be more in work. Furthermore, this tool will be used by the community in the Gading Kasri Village to be more beneficial for the organization or the general public.

Keywords

Biomass, alternative, energy, plastic, waste, distillation, gasification, economic

Article Received: 10 August 2020, Revised: 25 October 2020, Accepted: 18 November 2020

Introduction

Final Processing Site (TPA) is a place to collect trash from several temporary shelters (TPS). In Indonesia, currently, waste processing at TPA is carried out using open dumping methods and sanitary landfills. The available dumping method has been prohibited through Law number 18 of 2008 concerning Waste Management. With the issuance of this law and to overcome the increasingly urgent waste problem, Several studies have been conducted to design a friendly waste processing technologies environment (Perini et al. 2017). Initially, many countries used incinerators or heating technology. However, incinerator technology turns out to impact the form of dioxins and furans as a result of emissions that are very harmful to the human body. To tackle the incinerator's impact, experts have now discovered processing technology for the new waste, namely methane or bio-mass fermentation technology (Yadav 2015). Biomass technology is a clean energy technology that has been agreed upon by several countries in the Kyoto Protocol to develop a clean development mechanism. Biomass is organic material produced through photosynthetic processes, either in the form of products or waste.

One technology that uses biomass to produce energy is gasification technology. The supply of biomass raw materials in Indonesia is more than the source of other alternative fuels. The only challenge faced today is the cost efficiency collection of fabrics and mobilization of materials so that production costs are not too high (Zeng, Song, and Wang 2012). This technology provides excellent benefits to society and regional development, biomass and gasification technology growth must be accompanied by precise economic calculations (Parizeau, von Massow, and Martin 2015). The ESDM ministry's data states that the energy potential is generated from waste cities throughout

Indonesia reached 49,810 MW. The current installed capacity of biomass technology only 0.89 percent.

However, waste originating from plastic materials is always the primary source of the problem because it is difficult to process it into an energy source, therefore in this design, a "Combustion Optimization Tool Design for the Distillation of Plastic Waste into Fuel" was made in this design. In this design, a plastic waste burner cross-section is made in the form of a circular crossbar so that the volume of waste and the effectiveness of combustion that is collected can be more in work.

Theory

Several theories form the basis of this research, as presented in the following points :

2.1 Active Carbon

Activated carbon is an amorphous compound produced from materials containing carbon or charcoal, which are specially treated to obtain high adsorption power. Activated carbon can adsorb certain gases and chemical compounds or selective adsorption properties, depending on the pores and surface area's size or volume. The absorption capacity of activated carbon is substantial, namely 25-100% by weight of activated carbon (Morrissey and Browne 2004). Activated carbon can be divided into two types, namely: 1. Activated Carbon as Blanching Usually in the form of a fine powder with a pore diameter of 1000 Å, used in the liquid phase, and serves to remove disturbing substances. 2. Activated Carbon as a Vapor Absorbent Usually in the form of granular or very hard pellets, the diameter of the pore is 10-200 Å, generally used in the gas phase for solvent return, catalyst, and gas purification (Garner et al. 1972). In general, activated carbon/charcoal is used as a cleaning

agent and absorbent and is also used as a catalyst carrier (Morrissey and Browne 2004).

2.2 Plastic Waste

The use of plastic material from year to year has increased and requires a large space to accommodate it. The number of plastic products produced in Indonesia consists of Poly Propylene (PP), Poly Ethylene (PE), Poly Styrene (PS), Poly Vinyl Chloride (PVC), Acrylonitrile Butadiene Styrene (ABS), Poly Ethylene Terephthalate (PET), Low-Density Poly Ethylene (LDPE), High-Density Poly Ethylene (HDPE), and Styrofoam. The products are already produced locally. Plastic products will be discarded by consumers because they are no longer used as waste. Of the various plastic waste that exists, Plastic Waste from the types of High-Density Poly Ethylene (HDPE) and Poly Propylene (PP) is the most abundant and easy to find. Some types of plastic have a market value, but most plastic snack wrap has no market value (Waste Management 2003). Source or Origin of Waste According to Wahid Iqbal and Nurul C (2009: 276), sources of waste can come from [1] Residential areas are types of waste in food scraps, leftover materials from food processing or wet waste, dry waste, and ash. [2] Public places and trade centers are places of trading activity. The type of waste produced is in food scraps, residual building materials, and others. [3] Agriculture and livestock Waste derived from animals or plants can be in the form of perishable food scraps and insect repellent materials.

Method

3.1 Structural Equation Modeling (SEM)

The analysis method uses a mixed-method, which combines the analysis of descriptive qualitative and quantitative analysis. Descriptive qualitative research was used to explain the relationship between variables based on the respondent's opinion or idea to explore the potential of the region and society. Another analysis used SEM analysis to produce influence between the variables studied so that it is expected to be part of it in making decisions for poverty reduction programs. Analysis of Structural Equation Modeling (SEM) Statistical analysis using inferential statistics to test each indicator's strength in forming a variable, so it can be known which hand dominant in developing variables, by knowing the value of the factor loading each indicator against the variable. Also, the influence between variables will be known as independent and dependent variables. The analysis used in this study uses Structural Equation Modeling (Structural Equation Model or SEM) using packages AMOS 21 and SPSS Version 11.5 programs.

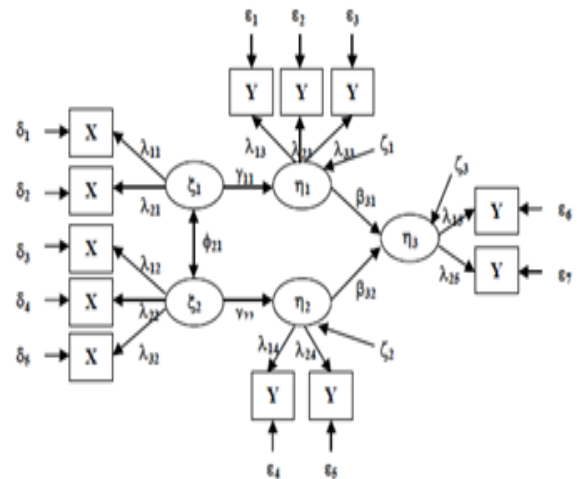

Figure 1. SEM Modeling

3.2 Design and Spesification

This tool has the following specifications, i.e., 1. Combustion Room I, 2. Distribution Pipe I (Between Combustion Room I and Filter Room I), 3. Filter Room I, 4. Condenser I (Between Filter Room I and Combustion Room II), 5. Combustion Temperature Indicator in Combustion Room I, 6. Drainage Residual Combustion, 7. Combustion Temperature Indicator in Combustion Room II, 8. Combustion Room II, 9. Condenser II (Between Combustion Room II and Storage Room), 10. Combustion Smoke Exhaust Pipe, 11. Burning Fume Exhaust Pipe to Smoke Minimizing Room, 12. Smoke Minimizing Room (filled with water to minimize combustion smoke), 13. Shelter Room (there is also a filter), 14. Faucets

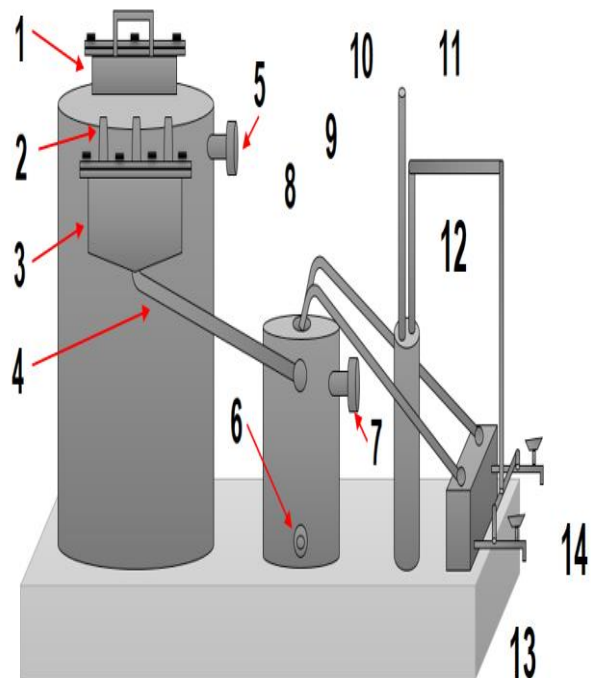

Figure 2. prototype design to convert plastic into fuel

The stages of the process can be seen at the following points, [1] The first thing that must be done is sorting plastic

waste because the type of plastic waste that will be processed will affect the output of the fuel to be released (clarity level). Plastic waste must be cleaned before burning. A suitable type of plastic waste for this tool is plastic waste from drinking mineral water bottles. [2] After sorting plastic scrap, plastic waste should be crushed into plastic ore because the firing process will be more optimal (there will be no plastic residue in the combustion chamber). The combustion capacity of this tool is + 10 kg. [3] Enter the plastic waste that has been crushed into Combustion Room I (+ 10Kg capacity) before burning the previous combustion exhaust in the drain. After there is no remaining combustion before, combustion can be carried out. The temperature in the combustion chamber, expected to be maximum (maximum temperature indicator). [4] Steam from combustion in the combustion room I will enter Filter Room I, Filter Room I contains activated charcoal, which can be replaced every six months. This activated charcoal is readily available at aquarium stores. [5] After passing through Filter Room I, the money from combustion will enter combustion room II. In this combustion room II the expected temperature is not more than 50 ° C. From combustion chamber II, the money from combustion will enter the Filter Room plus the Storage Room. [6] From the storage room, there is a channel to channel the smoke from the combustion residue to the Smoke Minimizing Room to minimize combustion smoke. [7] A Cooling Pipe reduces the heat from the combustion oil before it is distributed to the storage room. [8] There are two faucets in the storage room to channel oil from the storage room to the next reservoir.

Result

4.1 Testing of The Prototype

In this section, a trial will be carried out by entering the raw material for plastic waste. In this section, the plastics will be smelted to produce fuel. The amount of plastic will determine how many liters of energy are produced.



Figure 3. prototype succeeded in producing fuel

4.2 Analyzes

Table 1. Experiment for Recycling of Clear Plastic Waste from Mineral Water Bottles

Nu	Number of experiment	Garbage weight	Temperature (C)	Burning time (minute)	Fuel Type A (ml)	Fuel Type B (ml)	Fuel Type C (ml)
1	1	10	300	118	240	702	134
2	2	10	285	122	251	735	140
3	3	10	260	127	218	636	123
4	4	10	303	113	253	741	141
5	5	10	254	131	211	615	120
6	6	10	257	129	217	633	123
7	7	10	283	125	231	675	130
8	8	10	251	136	212	618	120
9	9	10	253	130	209	609	119
10	10	10	274	126	233	681	131
11	11	10	252	137	215	627	122
12	12	10	250	135	210	612	119
13	13	10	255	131	211	615	120
14	14	10	252	140	198	576	113
15	15	10	247	136	208	606	118

Table 2. The Experiment for Recycling of Cooking Oil Packaging Plastic Waste

Number of experiment	Garbage weight	Temperature (C)	Burning time (minute)	Fuel Type A (ml)	Fuel Type B (ml)	Fuel Type C (ml)
1	10	250	190	151	481	163
2	10	200	253	160	508	167
3	10	210	246	149	475	162
4	10	208	255	168	532	171
5	10	254	187	115	373	145
6	10	226	206	147	469	161
7	10	200	260	154	490	164
8	10	200	242	165	524	170
9	10	260	181	287	890	231
10	10	243	205	237	739	206
11	10	200	245	163	518	169
12	10	248	180	276	855	225
13	10	260	185	281	871	228
14	10	210	240	175	553	175
15	10	230	208	221	691	198

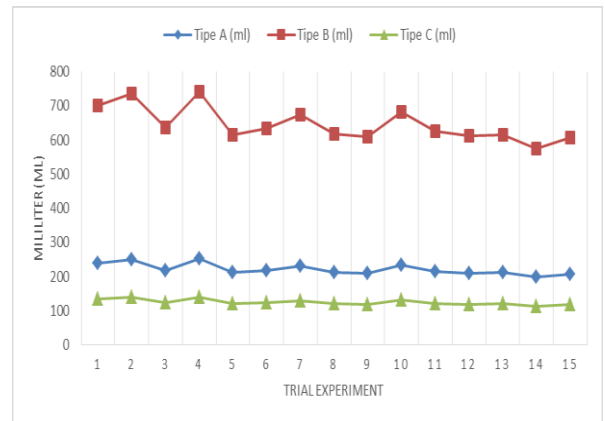

Figure 4. The experiment used a 10 kg drinking bottle or mineral water

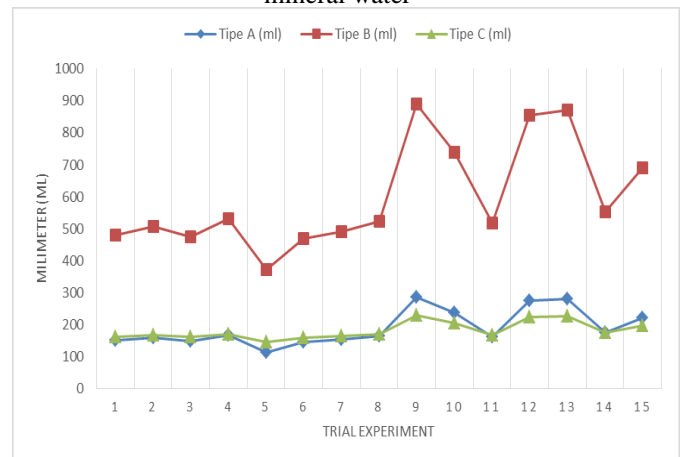

Figure 5. The experiment used 10 kg of cooking oil plastic waste

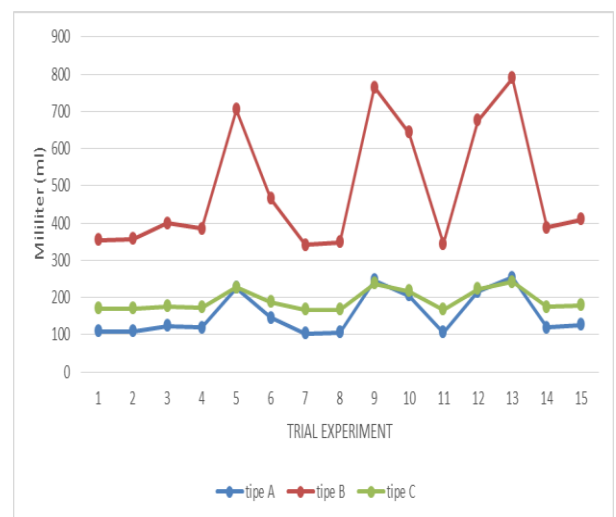

Figure 6. Experiment with various 10 kg plastic waste

Table 3. Experiment on recycling various types of plastics

Nu	Number of experiment	Garbage weight	Temperature (C)	Burning time (minute)	Fuel Type A (ml)	Fuel Type B (ml)	Fuel Type C (ml)
1	1	10	200	220	109	355	170
2	2	10	200	218	110	358	170
3	3	10	210	203	124	400	177
4	4	10	208	210	119	385	174
5	5	10	254	135	226	705	228
6	6	10	226	186	146	465	188
7	7	10	200	230	104	341	167
8	8	10	200	225	107	348	168
9	9	10	260	127	246	765	238
10	10	10	243	142	205	644	218
11	11	10	200	227	106	345	168
12	12	10	248	138	216	675	223
13	13	10	260	123	254	789	242
14	14	10	210	210	120	388	175
15	15	10	230	217	127	410	179

5.2 Comparison graph of output results in milliliters (ml) of 3 different types of fuel

Conclusion

Produce an energy source in the form of gasoil with a maximum volume compared to previous designs in similar devices. The fuel produced by this tool can be used to fuel lawnmowers and two-stroke motorcycle engines. It is essential to pay attention to sorting plastics before burning. The best is plastic waste from mineral water bottles. The main components consisting of Combustion Room I, Filter Room I, Combustion Room II, Filter Room + Storage

Room, Smoke Minimizing Room. Furthermore, The fuel produced by the tool made in this research is successful. The fuel produced needs a further refining process to deliver maximum filtering results to be used in cars and similar vehicles.

References

- [1] senberg, D., 2011a, The Entrepreneurship Ecosystem Strategy as a New Pradigm for Economy Policy: Principles for Cultivating Entrepreneurship, Babson Entrepreneurship Ecosystem Project, Babson College, Babson Park: MA
- [2] Japan Institute of Energy, 2012, Asia Biomass Handbook, Japan, JIE
- [3] Korhalliler,S.,2010, The UK's Biomass Energy Development Path, UK: International Institute for Environement and Development
- [4] Lazear, Edward P., 2005, Entrepreneurship, Journal of Labor Economics, 2005, vol 23, no 4.
- [5] Pahuja, A. and Sanjeev, R.,2016, Introduction to Entrepreneurship, Ghaziabad:IMS
- [6] Ramke, Hans Gunter, et.al, 2009, Hydrothermal Carbonization of Organic Waste, Prosiding Seminar "Twelfth International Waste Management and Sanitary Symposium, Italy: CISA Ppublisher
- [7] Tajali, Arief, 2015, Panduan Penilaian Potensi Biomasa Sebagai Sumber Energi Alternatif di Indonesia, Jakarta:Penabulu Alliance
- [8] Brunner, Paul H., and Helmut Rechberger. 2015. "Waste to Energy - Key Element for Sustainable Waste Management." Waste Management.
- [9] Garner, William et al. 1972. "WASTE MANAGEMENT RESEARCH."
- [10] Morrissey, A. J., and J. Browne. 2004. "Waste Management Models and Their Application to Sustainable Waste Management." In Waste Management,.
- [11] Parizeau, Kate, Mike von Massow, and Ralph Martin. 2015. "Household-Level Dynamics of Food Waste Production and Related Beliefs, Attitudes, and Behaviours in Guelph, Ontario." Waste Management.
- [12] Perini, João Angelo de Lima et al. 2017. "Optimisation of the Removal Conditions for Heavy Metals from Water: A Comparison between Steel Furnace Slag and CeO₂nanoparticles." Arabian Journal of Chemistry.
- [13] Waste Management. 2003. "Typical Anatomy of a Landfill." Wm.
- [14] Yadav, Reshu. 2015. "Solid Waste Management." Pollution Research.
- [15] Zeng, Zhao Xi, Bing Xue Song, and Qin Tao Wang. 2012. "A Literature Review on the Research of Circular Economy-Based Green MICE." Advanced Materials Research.